



*Opening of the 2005-2006 season*

**NANNI DIESEL LAUNCH ANOTHER LEADER OF ITS CLASS  
THE 4.200 TD 60 HP KUBOTA-BASED.**

**This autumn 2005, the 4.200 TD Kubota-based engine will be the spearhead of Nanni Diesel new product.**

The 4.200 TD is Nanni Diesel new 4 cylinders 2 liters turbo engine, using a brand new Kubota-based engine block. This engine is developing 60 HP at only 2800 rpm.

**Nanni Diesel and Kubota have manufactured it to be reliable, clean and incredibly quiet.**

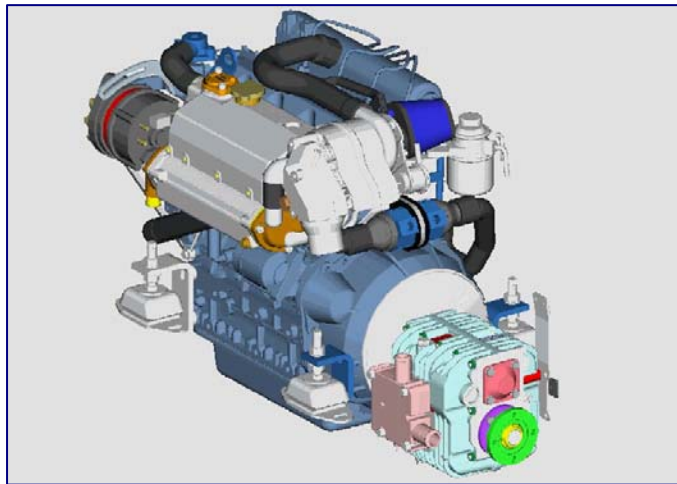

*4.200 TD 3D back\_view*

**Its important torque at lower rpm makes it perfect for sailing yachts – better handling in harbour and at sea.**

The 4200 TD can be continuously run without any power restriction. Therefore, it is particularly adapted for intensive conditions common in chartering or luxury sailing.

Another advantage for these specific uses : the 4200 TD - maintenance is easy and of low cost, with no electronics or complex injection system.

It can be supplied with a hydraulic or a mechanical gearbox as well as with a saildrive.

**The 4.200 TD uses the E-TVCS combustion-chamber** (a whirling combustion system) which, by optimising the gas combustion, creates a better efficiency in a major reduction of polluting emissions.

**The 4.200 TD is well within the CE 94/25 anti-pollution standards** (gas emission level more stringent than the new European 94-25 EEC standard).

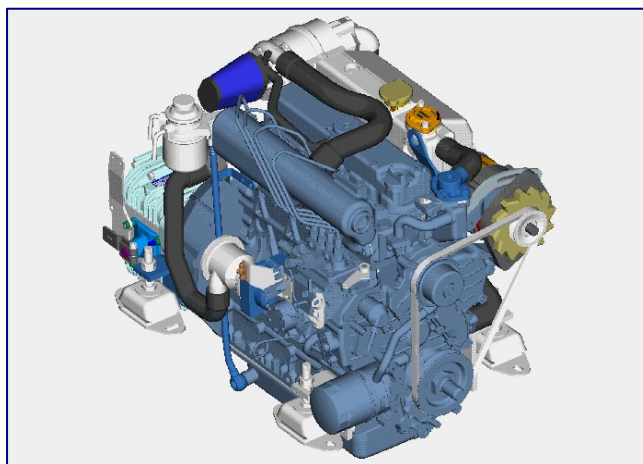

*4.200 TD 3D front\_view*

This new engine benefits from a three years Silverwake Guarantee, when used for cruising and from the worldwide Nanni Diesel service network.

Compact - Lightweight - Powerful - its dimensions : 67cm long by 50 wide and 68 high for a total weight of only 184 kgs.

### **Main specifications**

Base	Kubota
Power	(44,2 Kw) 60 HP
Engine speed	2800 t/mn
Displacement	1 999 litres
Number of cylinders	In-line 4
Bore / Stroke	83 x 92,4 mm
Compression ratio	22 / 1
Combustion	Indirect injection (E-TVCS)
Aspiration	Turbo compressed
Cooling system	Double circuit with heat exchanger
Alternator	14 V - 100 Amperes
Panel	B3
Gear box	TMC /ZF mecanic or hydraulique
Weight	234 kg
<b><u>Connections</u></b>	
Exhaust	60 mm
Fuel pipe (aspiration & return)	10 mm
Sea water	25 mm
Installation angle	15° (dynamic)

## NANNI DIESEL IN A FEW WORDS

An European company, Nanni Diesel conceives, develops, builds and distributes a large range of marine engines, from 10 to 1500 hp.

Based in France, at La Teste near Bordeaux, that Nanni Diesel production site adapts and converts for boats and the marine environment engines bases coming from the world largest specialists such as Toyota, Kubota and MAN.

Nanni Diesel distributes the largest MAN units (develop up to 1500 HP) in France and French speaking countries, and the Daewoo engines, for professional and fishing boat applications.

Nanni Diesel now offers a full range of marine engine solutions for fast cruising craft, fishing boats, luxury sailing yachts and inland waterways charter boats.

When comparative tests are being made Nanni Diesel engines have proved to be the best option for many boats - resulting in standard fitment and preferred choice of more and more prestigious boatbuilders - producing a great commercial success.



**The 'green' engines are blue** : Nanni Diesel is aiming to be the cleanest marine engine builder.

### Main information to keep in mind,

→ This year 2005, Nanni Diesel forecasts a turnover of around **€28 million**, up by **18%** compared to 2004.

The turnover and sales of engines have almost doubled within the last five years.

→ Export activities now represent **50% of the global turnover**.

## NANNI DIESEL'S PRESENCE AT THE BOAT SHOWS THIS AUTUMN 2005

<i><b>Boat shows</b></i>	<i><b>Dates</b></i>
Ijmuiden (Holland)	30 august to 4 september
La Rochelle (France)	7 to 12 september
Cannes (France)	14 to 19 september
Newport (USA)	15 to 18 september
Southampton (UK)	16 to 25 september
Friedrichshafen (Germany)	24 september to 2 october
Annapolis Sail (USA)	6 to 10 october
Gènes (Italy)	8 to 16 october
Annapolis Power (USA)	13 to 16 october
Miami (USA)	19 to 21 october
Barcelone (Spain)	22 to 30 october
Hambourg (Germany)	29 october to 6 november

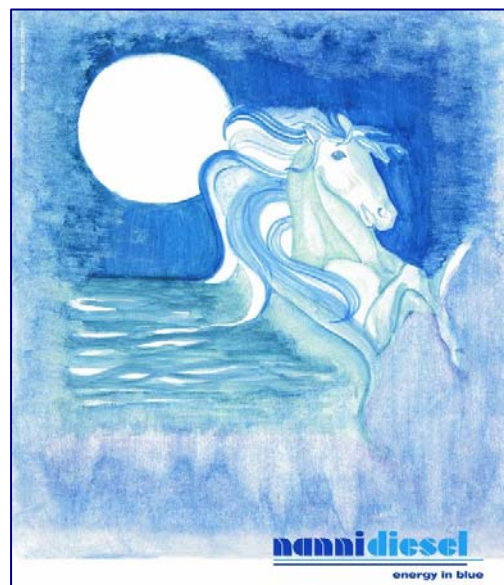

## NANNI DIESEL IN OFFSHORE RACES

This 2005 season, Nanni Diesel is taking part in offshore races with a Mediterranean Team: Mauro Piani, the Italian sports manager, José Romero Ruiz, the Spanish technical assistant and Pietro d'Ali, an experienced Italian skipper who represented his country during the 2000 Sydney Olympic games, and won the Louis Vuitton cup as a crew member aboard Luna Rossa.



### A remarkable beginning of season in 2005

- ✿ **1<sup>st</sup>** in the Massilia Cup (11 to 13 march / Marseille)
- ✿ **4<sup>th</sup>** in the Roma Per Due (16 to 24 april / Italy) with Ferdinando Colaninno, co-skipper
- ✿ **Winner** Gruissan leg  
*It is the first time that a foreigner wins a regatta in the Mediterranean Figaro circle since 16 years,*  
**1<sup>st</sup>** in the Bizuths results ad **7<sup>th</sup>** in the general results in the Generali Solo (6 to 25 june)

### New leg, the Solitaire Afflelou Le Figaro...

...after the « 18 heures d'Arcachon » on the 2<sup>d</sup> et 3<sup>rd</sup> of july (close to the Nanni Diesel's industrial site - Aquitaine).

*With this engagement, Nanni Diesel wishes to bring its support to the development of this type of boat in Southern Europe and particularly in Italy.*

## NANNI DIESEL INFORMATION

Visiting our website, you will find some high-resolution digital pictures  
you can use free of charge

[www.nannidiesel.com](http://www.nannidiesel.com)



### Marie-Christine Descamps / Céline Gordon

46-48, rue Lauriston 75116 Paris

Tél : 01 53 65 37 96 / Fax : 01 53 65 68 60 / Port : 06 07 70 13 18

Email : marie.mcd@calyptus.net / celine.gordon@calyptus.net

### Nanni Trading S.r.l. / Adele Pol

A.G. Bragaglia, 31/A 00123 Roma – Italie

Tél : +39 06 30 88 42 51-2-3 / Fax : +39 06 30 88 42 54

Email : adele.pol@nannidiesel.com

**Nanni Industries** - Z.I. - 11, avenue Mariotte - 33260 La Teste - France

Tél. +33 (0) 5 56 22 30 60 - Fax. +33 (0) 5 56 22 30 79

[www.nannidiesel.com](http://www.nannidiesel.com)

**Nanni Trading** - Via A.G. Bragaglia, 31/A - 00123 Rome - Italie

Tél. +39 06 30 88 42 51/2/3 – Fax. +39 06 30 88 42 54

[info@nannitrading.it](mailto:info@nannitrading.it) – [www.nannitrading.it](http://www.nannitrading.it)